

## 2004-2009 Mazda RX-8 Clutch Pedal Bracket SSP82

### 2004-2009 Mazda RX-8 Clutch Pedal Bracket SSP82

#### A. OVERVIEW

On certain 2004-2009 RX-8 vehicles, it is possible that the clutch pedal bracket may have a crack, causing an abnormal noise. If the clutch pedal continues to be operated with this condition, the clutch pedal bracket may break, changing the disengagement point of the clutch and possibly preventing the shifting of gears. The warranty coverage for the clutch pedal assembly (replacement of the clutch pedal assembly due to a problem with the clutch pedal bracket) on these vehicles is extended to 8 years (96 months) from the warranty start date, with a 100,000 mileage limitation.

#### B. VERIFY THE VEHICLE NEEDS THE SSP

1. Verify the vehicle is within the following VIN and Production Date Ranges.

Model	VIN Range	Production Date Range
2004-2009 RX-8	JM1 FE17** 40 100053 – 140891 JM1 FE17** 50 140892 – 161178 JM1 FE17** 60 200012 – 207471 JM1 FE17** 70 207474 – 214011 JM1 FE17** 80 214012 – 216609 JM1 FE17** 90 400032 – 402408	April 10, 2003 through September 13, 2008

- If the vehicle is within the above ranges, proceed to Step 2.
  - If the vehicle is not within the above ranges, it is not applicable to SSP82.
2. Perform a Warranty Vehicle Inquiry using your eMDCS System. Refer to eMDCS System - Warranty Vehicle Inquiry Results table.

#### eMDCS System - Warranty Vehicle Inquiry Results

If eMDCS displays:	Action to perform:
SSP82 OPEN	Proceed to "C. REPAIR PROCEDURE."
SSP82 is not displayed	SSP does not apply to this vehicle.

## **C. REPAIR PROCEDURE**

### **Outline**

Inspect the clutch pedal bracket for damage/breakage.

OK	Reinstall the original clutch pedal following the "Reinstallation Procedure".
NOT OK	Replace the clutch pedal with a modified one following the "Clutch Pedal Replacement Procedure."

### **Clutch Pedal Inspection Procedure**

1. Remove the clutch pedal nut (A) as shown.

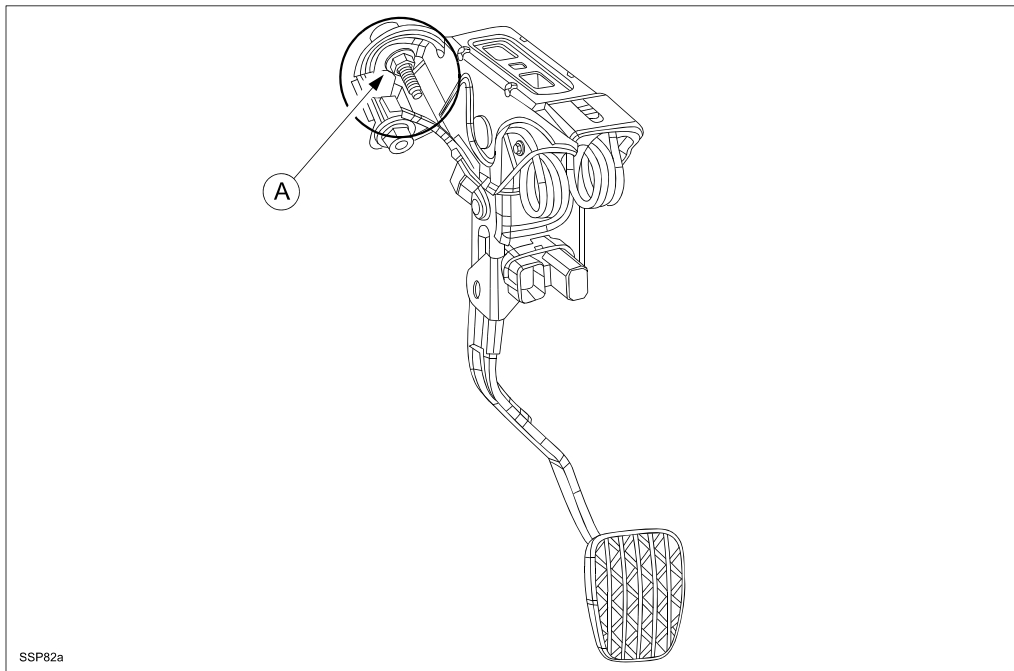

SSP82a

**ATTACHMENT II**  
**SSP82**

2. Inspect the clutch pedal bracket where the nut was removed to see if it is damaged or broken.
- If there is no damage or breakage, reinstall the clutch pedal following the “Reinstallation Procedure.”
  - If there is damage or breakage found, replace the clutch pedal following the “Clutch Pedal Replacement Procedure.”

**NOTE:** The pictures below show the clutch pedal component itself just to indicate an example of the damage. Clutch pedal component removal is NOT required in this step.

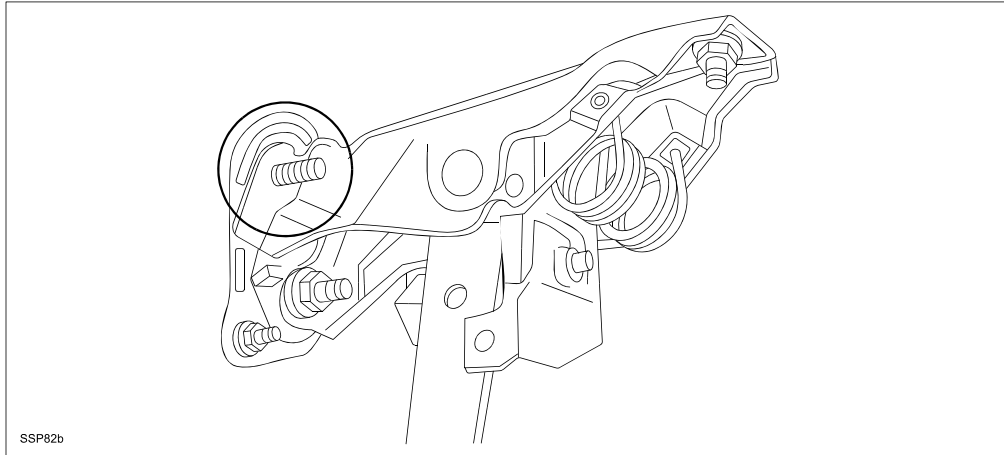

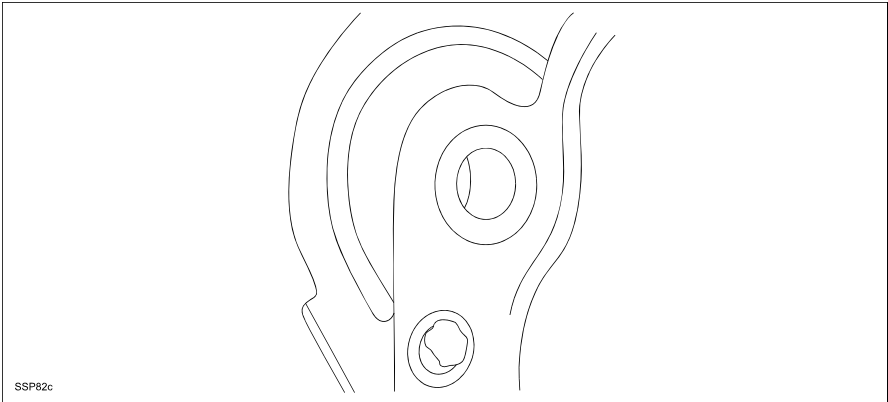
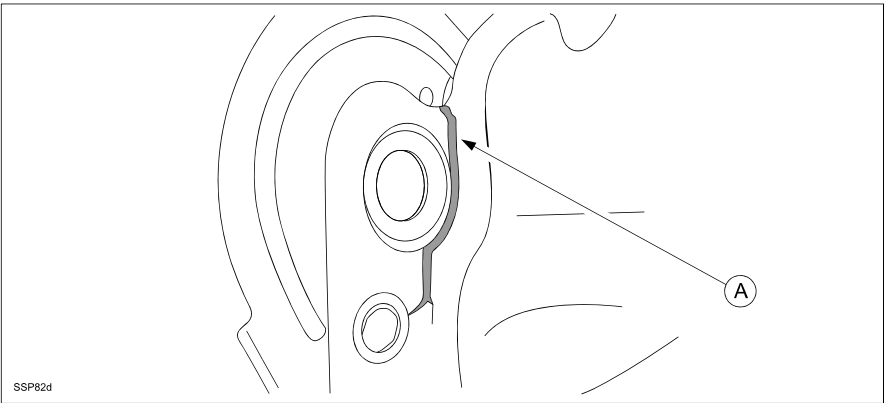
<p><b>OK</b> No damage or breakage found on the bracket.</p>	 <p>SSP82c</p>
<p><b>NOT OK</b> Breakage or damage (A) found on the bracket.</p>	 <p>SSP82d</p>

**Reinstallation Procedure (When no damage or breakage is found on the bracket)**

1. Loosen the other two nuts (A and B) on the clutch pedal.

**NOTE:** DO NOT remove the nuts. Just turn them counterclockwise once to loosen.

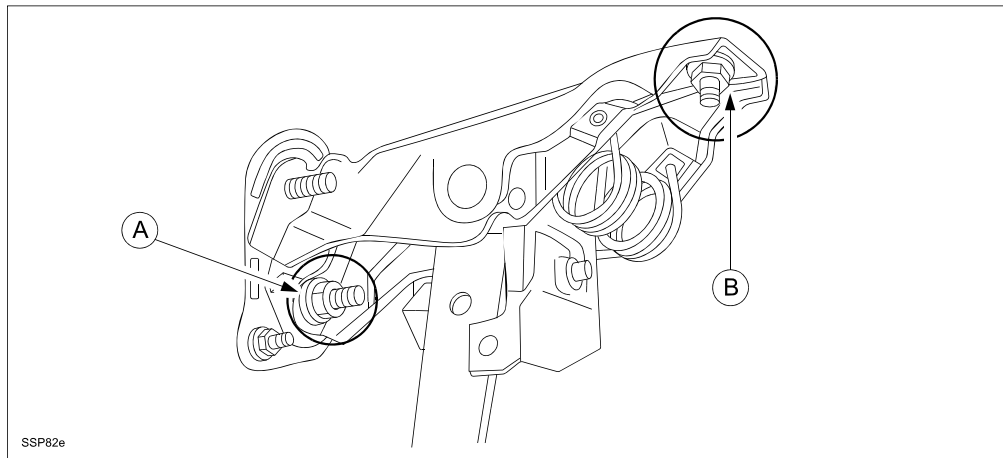

2. Tighten the nuts (A) first, then tighten the nut (B).  
**Tightening torque: 18.6-25.5 Nm (13.7-18.8 ftlbs)**

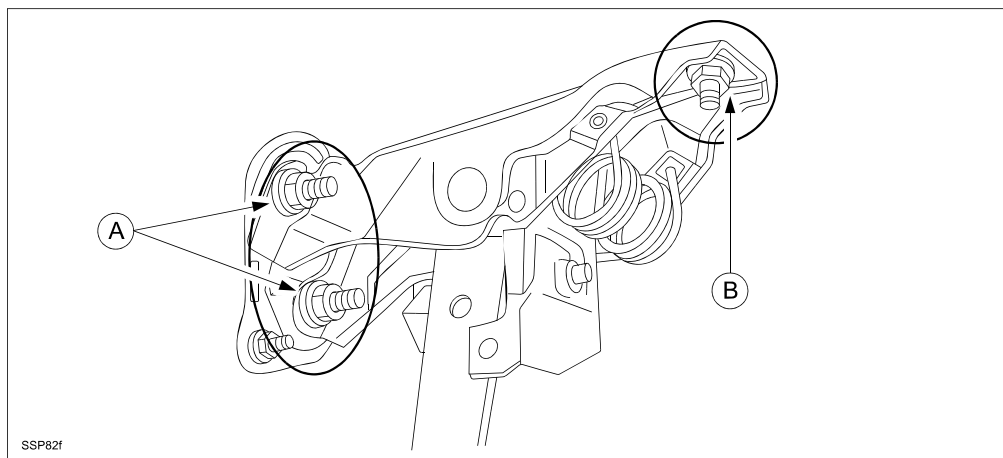

**Clutch Pedal Replacement Procedure (When damage or breakage is found on the bracket)**

1. Disconnect the negative battery cable.
2. Remove the clutch pedal component in the order shown.

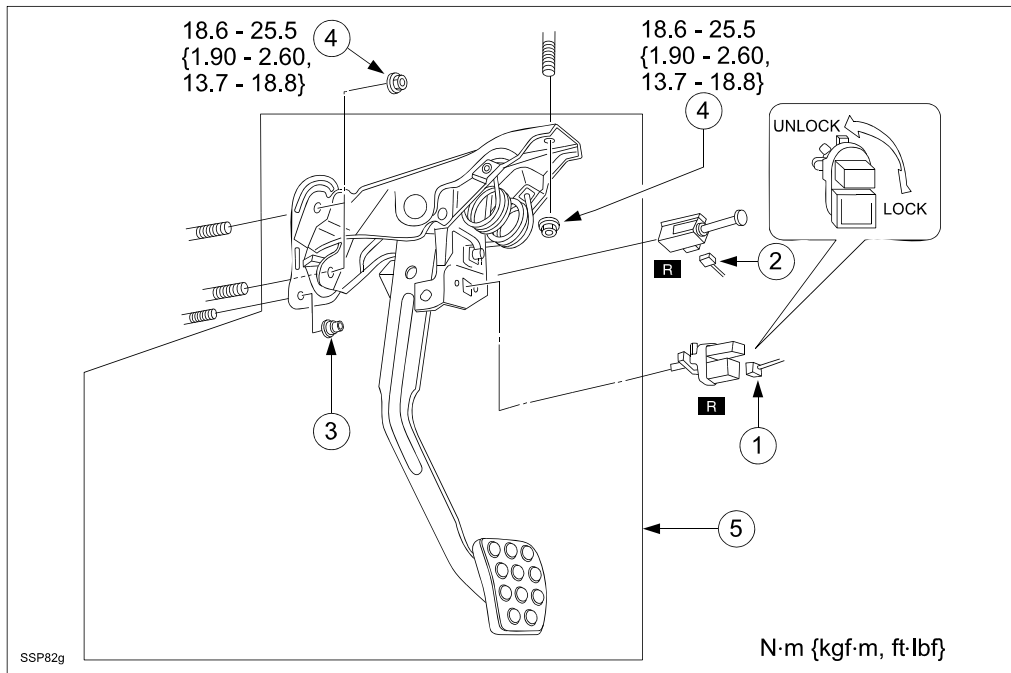

1	Clutch pedal position switch connector
2	Starter interlock switch connector
3	Clip
4	Nut
5	Clutch Pedal Component
	Clutch pedal position switch ( DO NOT reuse)
	Starter interlock switch connector (DO NOT reuse)

**ATTACHMENT II**  
**SSP82**

**NOTE:** To disconnect the clutch pedal position sensor, follow these steps.

- a. Turn the clutch pedal position switch (A) counterclockwise to remove it from the clutch pedal.

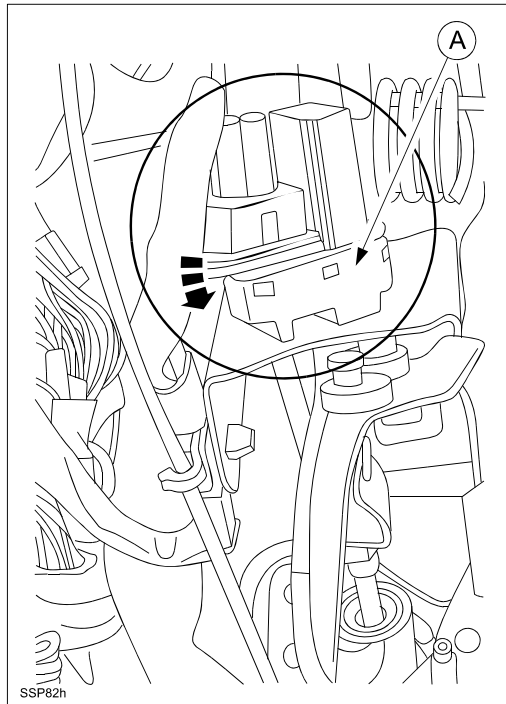

- b. Using a flathead screwdriver with a 2mm width (A), remove the pin (B) installed on the clutch pedal position switch to disconnect the connector.

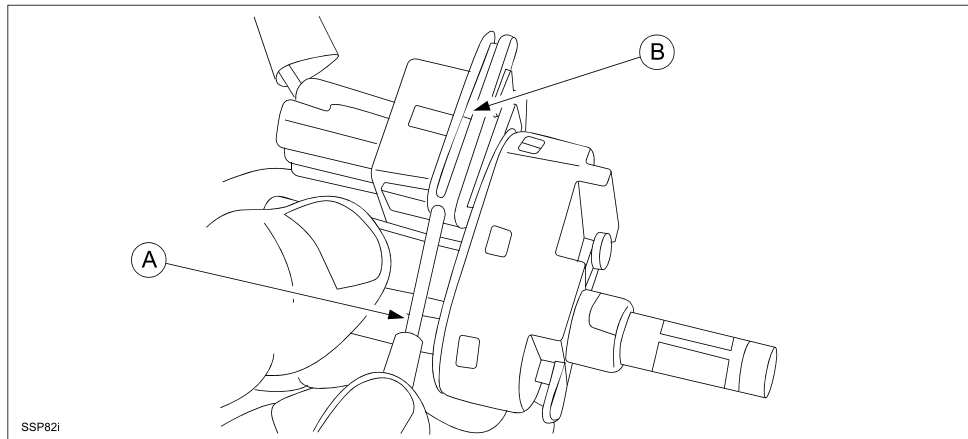

**ATTACHMENT II**  
**SSP82**

- c. After disconnecting the clutch pedal position switch connector, attached the removed pin (A) and discard the removed clutch pedal position sensor.

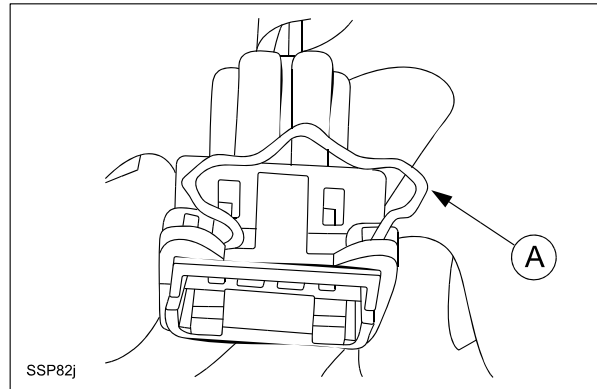

3. Install a modified clutch pedal and tighten the nuts in the order shown below (a, b, c).

**NOTE:** Make sure to follow the tightening procedure. Failure to do so may result in deformation of the bracket.

- a. Temporarily hand-tighten nut (B).
- b. Tighten nuts (A).
- c. Tighten nut (B).

**Tightening torque: 18.6-25.5 Nm (13.7-18.8 ftlbs)**

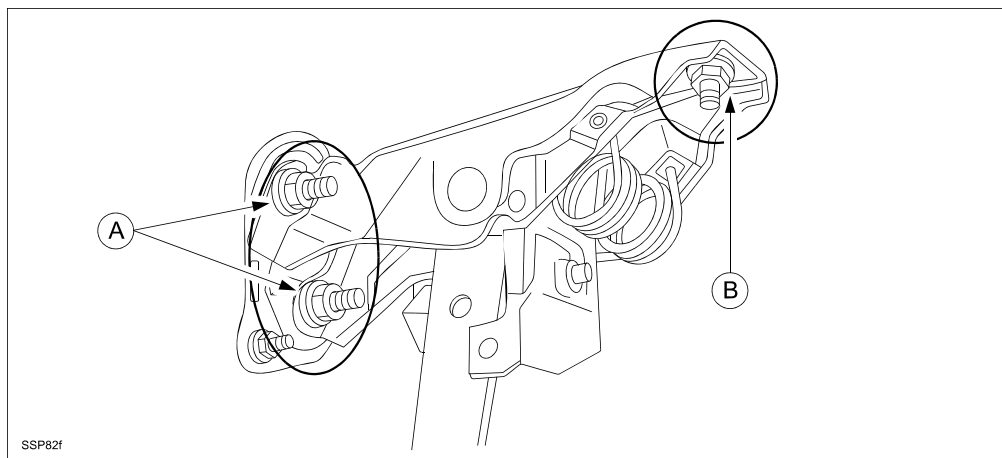

4. Adjust the clutch pedal play as follows.
- a. Lightly depress the clutch pedal by hand until resistance is felt, then measure the pedal play (A).  
**Clutch pedal play:** 5-15mm (0.20-0.59 in)  
**Clutch pedal push rod play:**  
At push rod setting line (Reference value): 0.1-0.5mm (0.004-0.020 in)  
At pedal pad: 0.5-2.9mm (0.020-0.110 in)

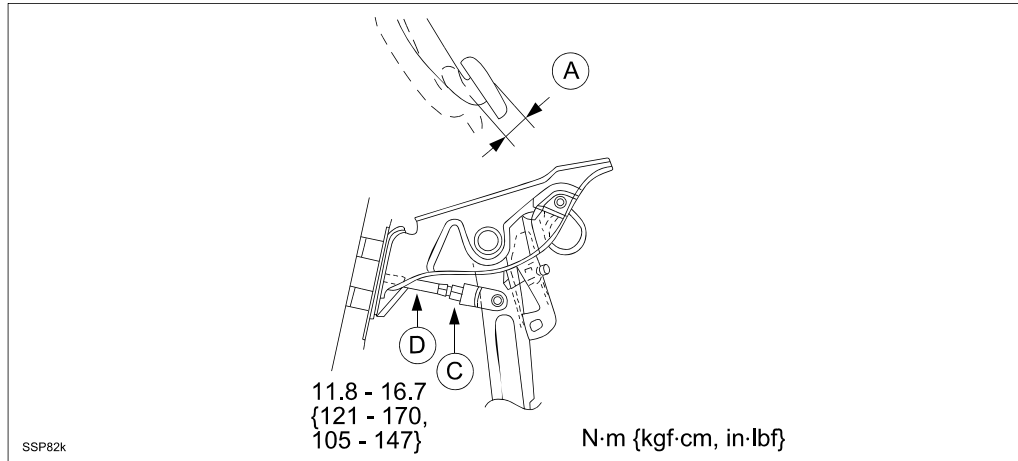

- b. If not within specification, loosen the locknut (C) and turn the push rod (D) to adjust the pedal play.
  - c. Measure the pedal play. If within specification, tighten the locknut (C).
5. Install a new clutch pedal position switch and new starter interlock switch.

**NOTE:** To install a starter interlock switch, follow these steps. DO NOT push the rod (A) into the switch during the installation, otherwise it may result in a malfunction of the switch.

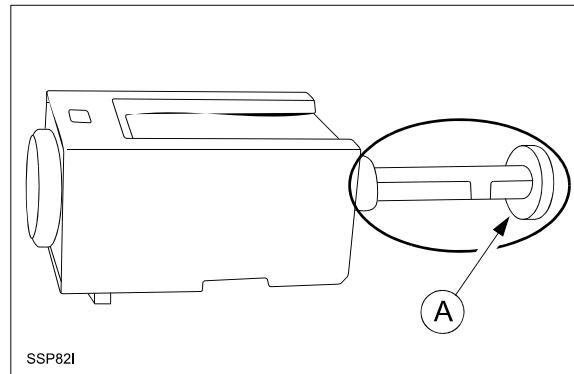



**ATTACHMENT II**  
**SSP82**

- a. Insert a new starter interlock switch into the open holes on the pedal bracket (A) as indicated by the arrow.

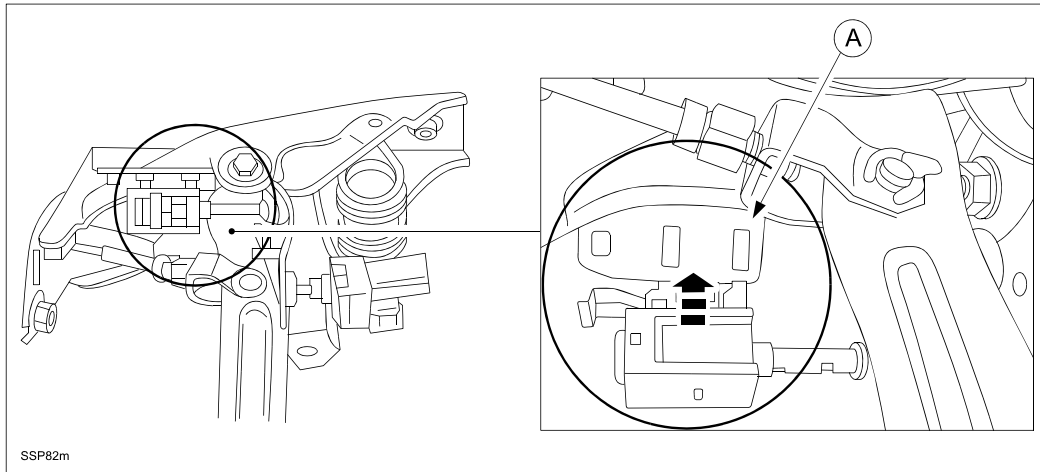

- b. While pushing the starter interlock switch to the bracket as indicated by arrow (A), slide the switch as indicated by arrow (B) until it locks.

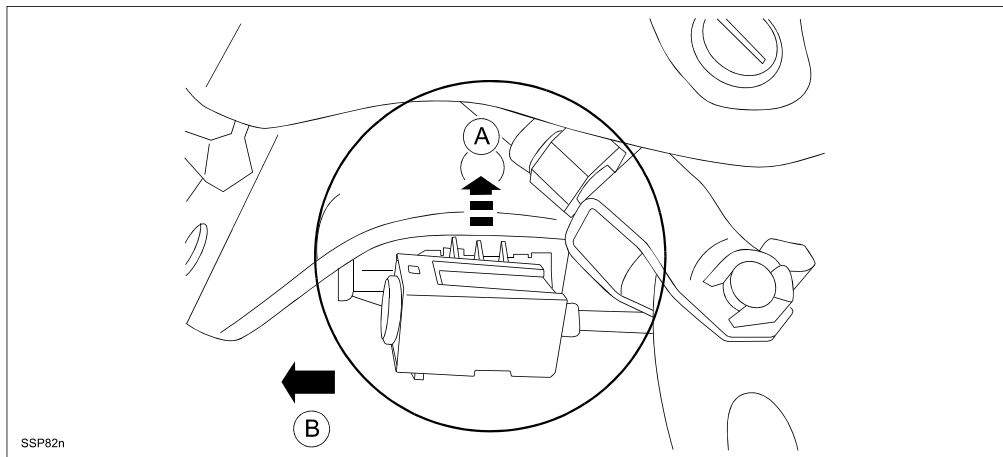

- c. Fully depress the clutch pedal.  
6. Connect the negative battery cable.